

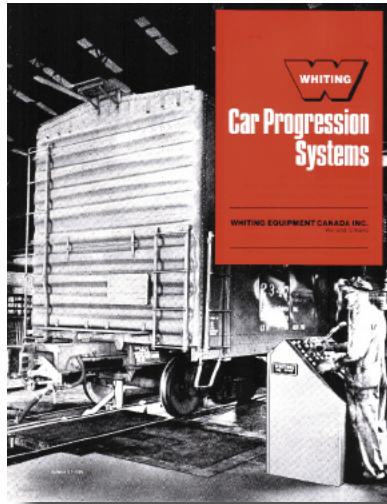

## Whiting Equipment Canada Inc. Car Progression Systems

---



# PROGRESSIVE SPOT REPAIR SYSTEM

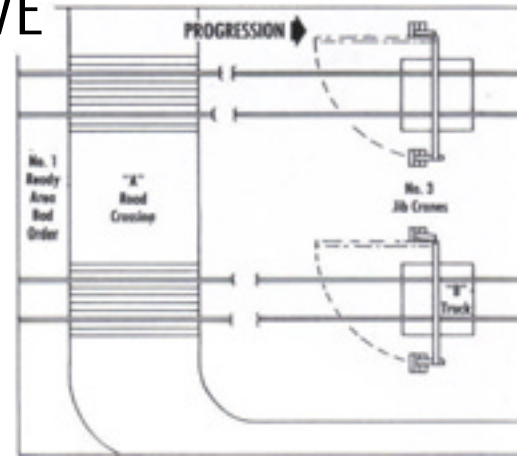

## Imaginative

## Engineering of rail car

progression systems is a cultivated habit at Whiting. The continuing development of new car moving equipment, plus fresh concepts in use of time-tested units, have tallied significant customer savings in an interesting range of applications.

These pages present some typical Whiting systems for moving rail cars more efficiently. They also offer detailed specifications for standard Whiting car pullers.

If you are planning new or modernized facilities, there is a wealth of experience available to you. Just contact our Transportation Equipment Division for a conference at your convenience.

# HOPPER CAR WASHING SYSTEM

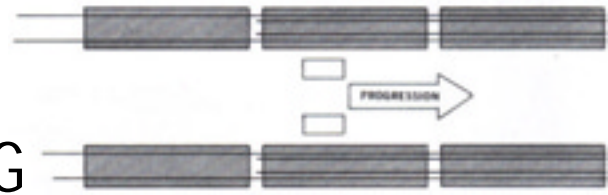

# RAPID TRUCK CHANGEOUT SYSTEM

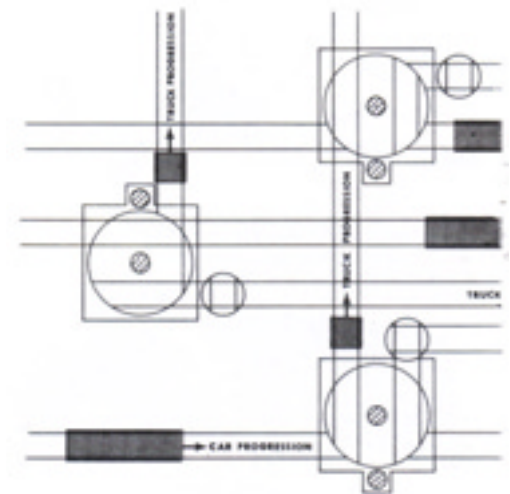

Bad order cars are progressed from a ready area to a Spot Repair Station, then on to an "O.K." area. The station is equipped with Whiting Ripjacks and jib cranes with hoists for holding truck frames and bolsters, plus automatic hose reels for oxygen, acetylene, oil and air. Car movement can be accomplished by a standard Whiting Car Puller, a remote controlled ROBOT system or a Trackmobile. A survey of your needs will determine the best solution.

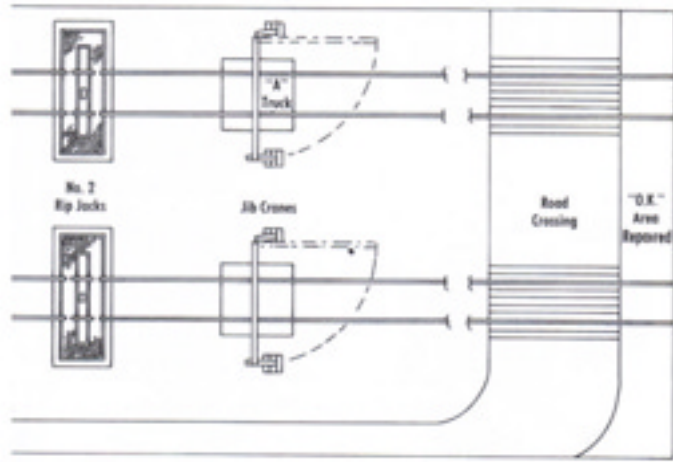
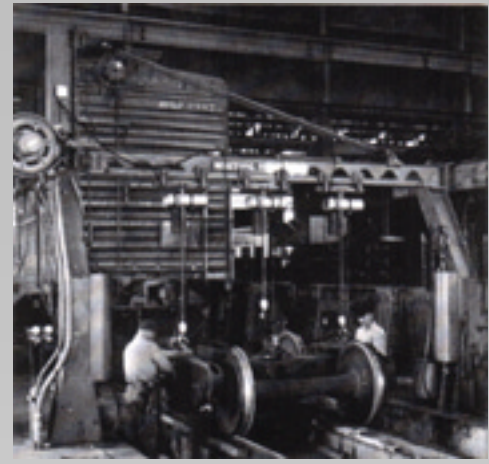

Two 48-car trains of empty hopper cars are progressed alternately in two-car increments through a wash station where their interiors are flushed clean of residue by high-pressure rotating jet nozzles lowered from underhung Whiting cranes. A Whiting ROBOT Remote Controlled Progression System is utilized in this installation.

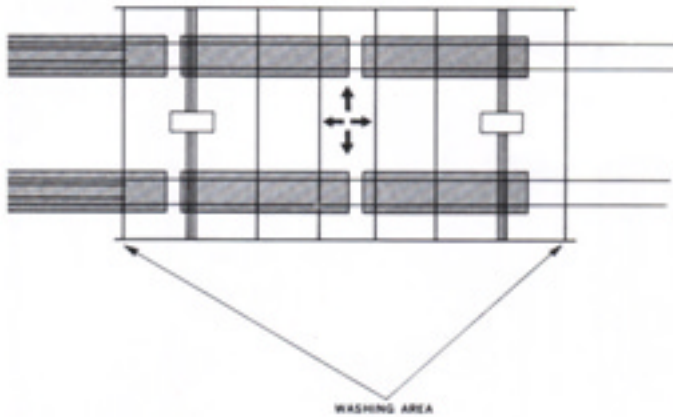

Whiting Jacks and Turntables can be teamed with a choice or combination of our talented car progression techniques to help a single operator place new car trucks in 90 seconds! An analysis of your requirements will indicate the most effective and economical arrangements.

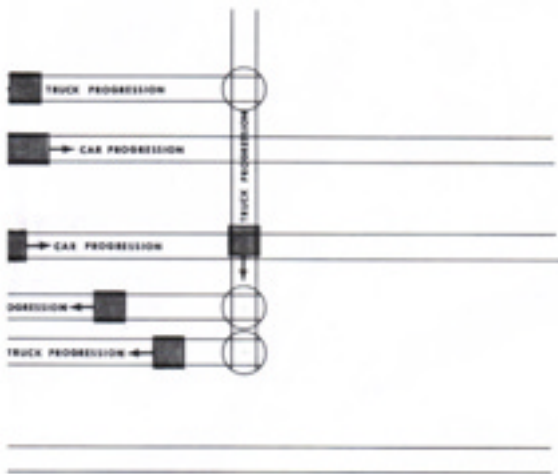
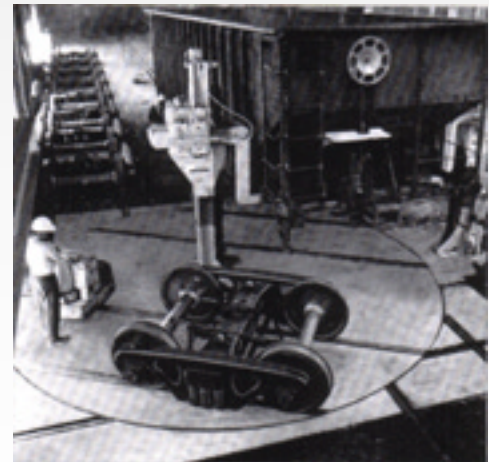

# WHITING ROBOT

## ***Remote Control Car Progression Systems***

The most significant breakthrough in Whiting car moving techniques has been development of our ROBOT Remote Control System. It utilizes endless rope Car Pullers and wheeled devices in double channel track.

It features robot arms that raise to contact axle or journal of cars to be moved. Highly efficient and versatile, it can be installed in virtually any car progression system to provide the following advantages:

- Remote control of entire progression system from central console
- Automatic cycling of progression sequences
- No cables to handle—no hooks to slip loose
- Puller rope completely enclosed for safety
- Automatic car indexing

*Photos and diagrams on the following pages illustrate standard ROBOT components. We will be pleased to discuss the ROBOT concept in light of your particular requirements.*





Progression of cars through shop workstations is a popular ROBOT application. Enclosure of puller ropes is added safety factor.

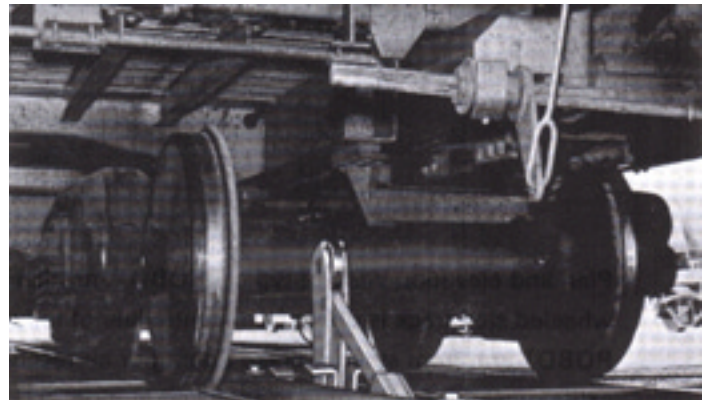

ROBOT arms ride in covered track between rails, rise to contact axle, side frame or coupler, according to design.



*Above and right -* Continuous rope pullers, installed with counterweight towers, provide the muscle for Whiting ROBOT Systems.



# WHITING ROBOT (cont'd)

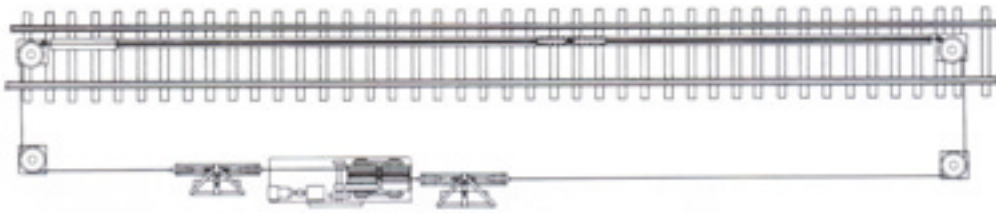

Plan and elevation view of typical ROBOT installation. Note that wheeled sled track is offset from center line of rail gauge to prevent ROBOT arm from striking brake rigging or air reservoir. Return cable outside of rail gauge is enclosed in pipe.

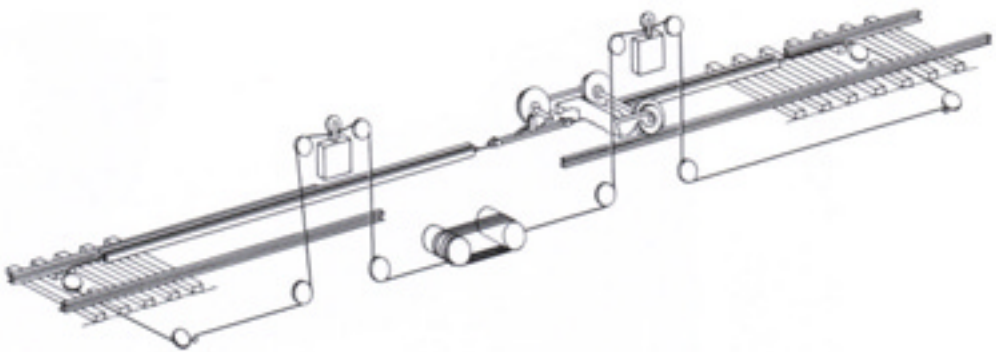

View of ROBOT system at inbound end of shop shows offset sled channels. Counterweight towers for endless rope pullers are located beside tracks.

Whiting ROBOTS are available in models for virtually any application. Three of the most common track and arm arrangements are as shown.

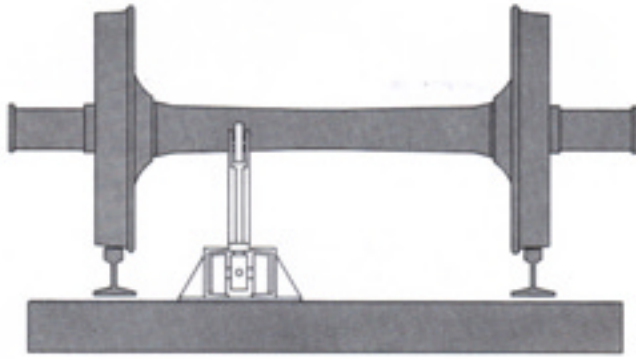

Single arm contacting axle. Recommended for draw bar pulls up to 35,000 lbs.

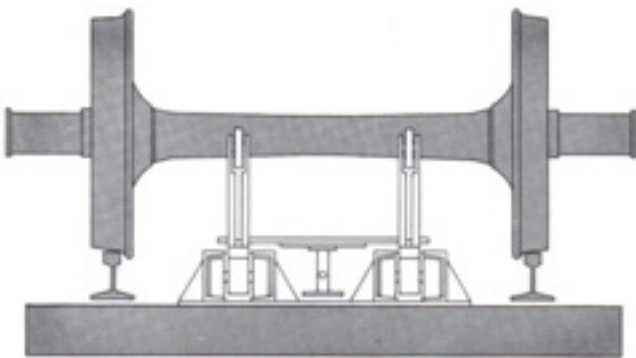

Double arm contacting axle. For draw bar pulls of 35,000 to 70,000 lbs.

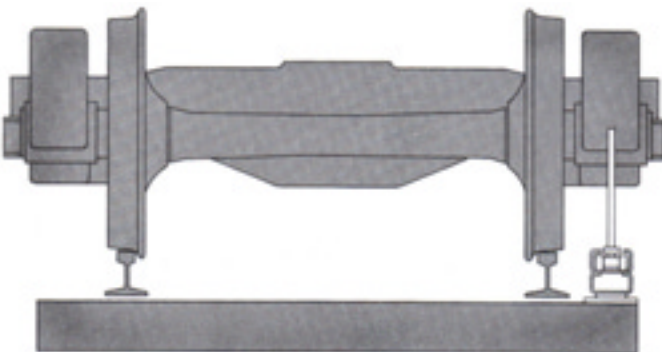

ROBOT arm contacting journal. For use when there are pits, scales, hoppers or other obstructions between rails.



# GENERAL PURPOSE PULLER

## Spool Type with Clutch

The Whiting general-purpose car puller designed for single line pull is available in capacities up to 10,000 pounds. The frame of all welded structural steel construction is designed to accept all components resulting in a compact, easily installed unit. Electric motor is of high torque type with push button control. Antifriction bearings are used throughout. Jaw clutch disengages the drive and allows the wire rope to be paid out quickly.

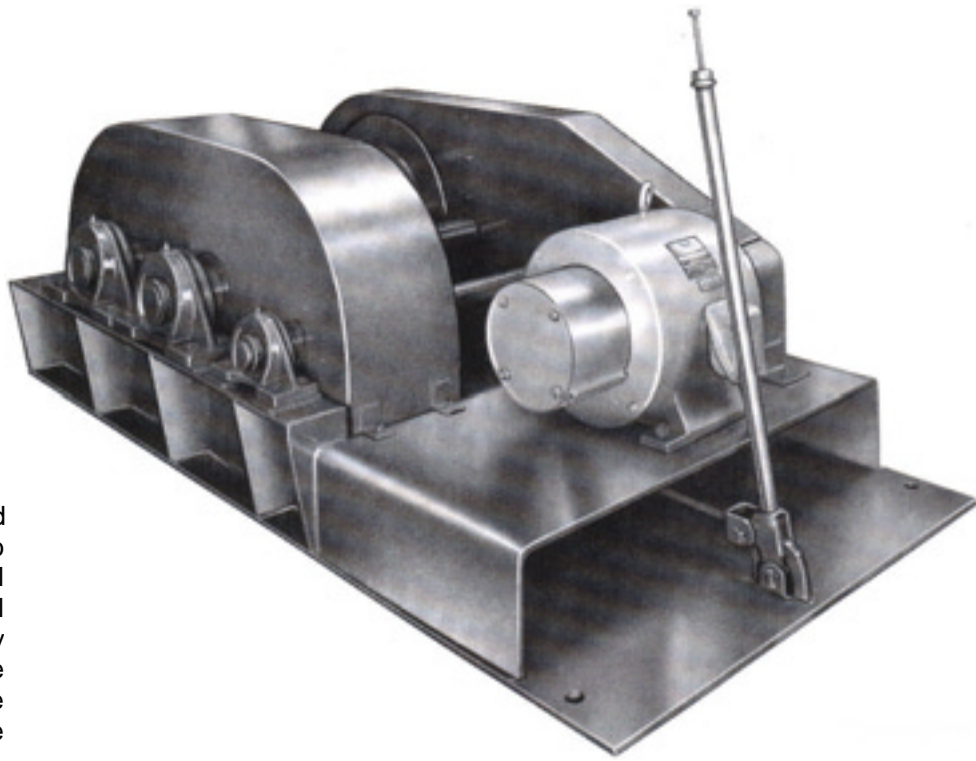

## Typical Layout

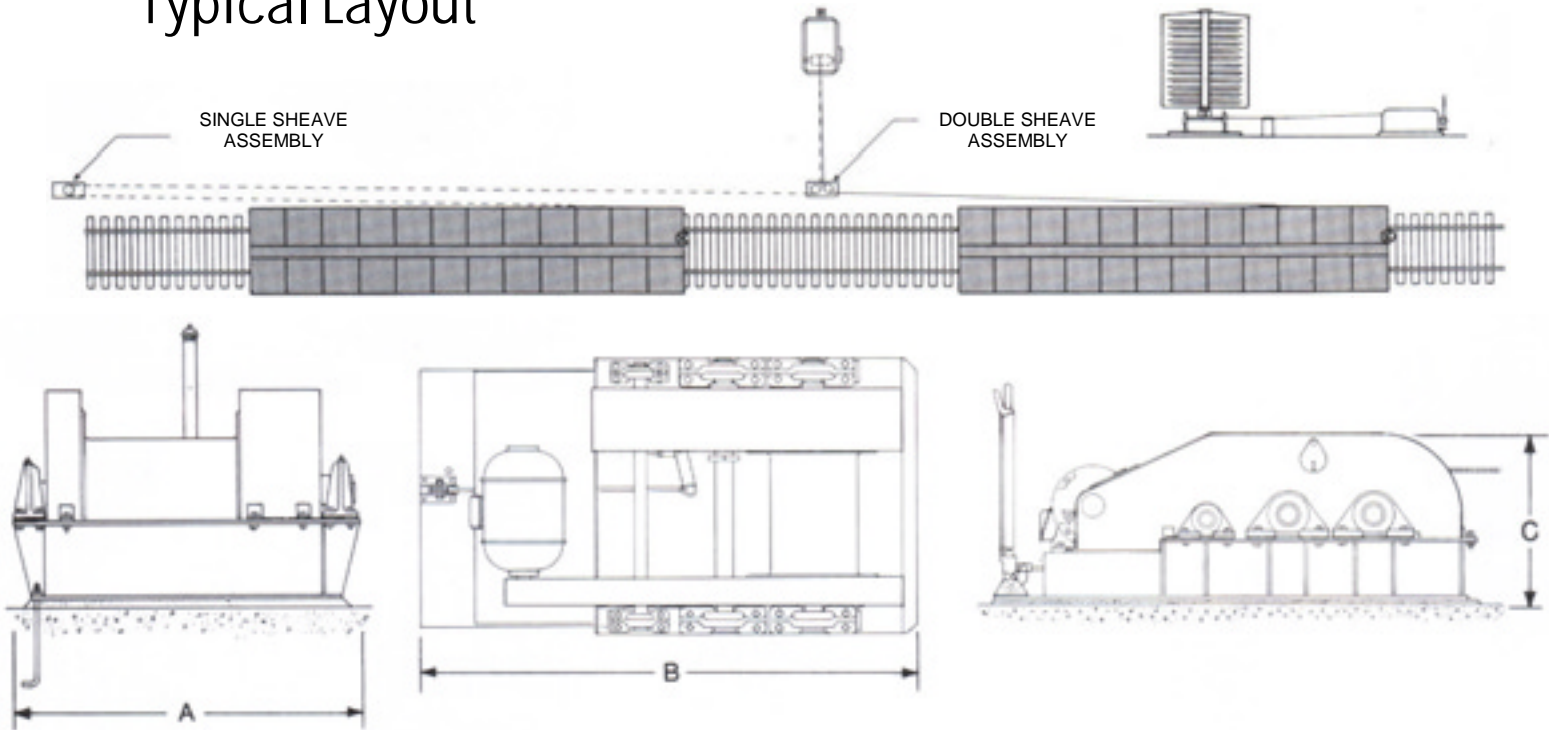

GENERAL PURPOSE PULLER – Spool Type With Clutch								
Capacity		Average Line Speed f.p.m.	H.P.	Rope Cap. 4 Wraps	Rope Size	A	B	C
Run	Start							
5,000	10,000	45	10	660'	1/2"	4'2"	7'4 1/2"	2'5 1/2"
7,500	15,000	45	15	560'	5/8"	4'2"	7'4 1/2"	2'5 1/2"
10,000	20,000	45	20	475'	3/4"	4'2"	7'4 1/2"	2'5 1/2"



# SINGLE DRUM ROPE PULLER

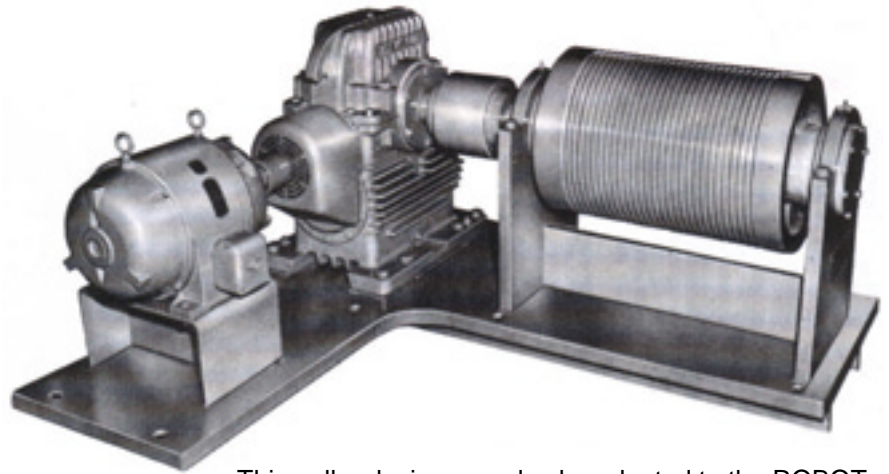

These units are ideally suited for applications in the medium pull ranges where forward and reverse car movement may be required over relatively short distances. All machinery is factory mounted and aligned on a common structural steel frame. Antifriction bearings are used throughout. The electric motor provided is of the ball bearing, high torque type with the horsepower rated as required by capacity and speed.

This puller design can also be adapted to the ROBOT car mover described on Pages 4-7. Available in two sizes with starting pull of up to 25,000 lbs. The single grooved drum unit is designed to minimize rope handling where relatively heavy cable must be used.

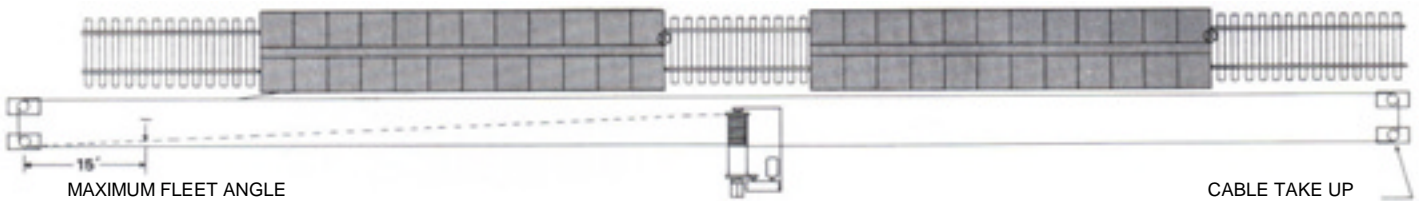

CARS MAY BE PULLED IN EITHER DIRECTION

## Typical Layout

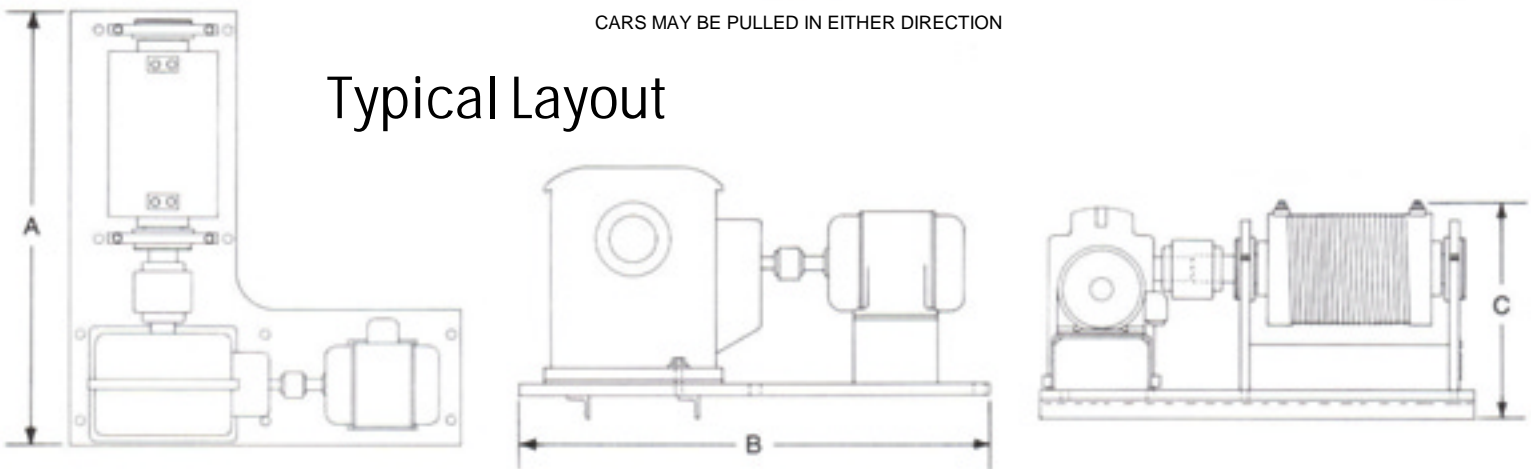

SINGLE GROOVED DRUM PULLER – 2 ROPE								
Capacity		Average Line Speed f.p.m.	Travel Cap.	H.P.	Rope Size	A	B	C
Run	Start							
650	1,300	30	127'	1 ½	½"	5'10½"	5'4"	26 <sup>1</sup> / <sub>8</sub> "
1,700	3,400	31	127'	3	½"	5'10½"	5'4"	26 <sup>1</sup> / <sub>8</sub> "
3,000	6,000	32	127'	4	½"	5'10½"	5'4"	27 <sup>7</sup> / <sub>8</sub> "
3,000	6,000	32	127'	5	½"	5'10½"	5'4"	27 <sup>7</sup> / <sub>8</sub> "
5,000	10,000	31	99'	7 ½	5/8"	6'1"	5'4"	31 <sup>7</sup> / <sub>8</sub> "
5,000	10,000	26	99'	7 ½	5/8"	6'1"	5'4"	34"
12,500	25,000	38	300'	25	7/8"	5'10 <sup>1</sup> / <sub>8</sub> "	8'5"	3'10"
12,500	25,000	38	300'	25	7/8"	7'10 <sup>7</sup> / <sub>8</sub> "	8'5"	3'10"

# DOUBLE DRUM CONTINUOUS ROPE PULLER

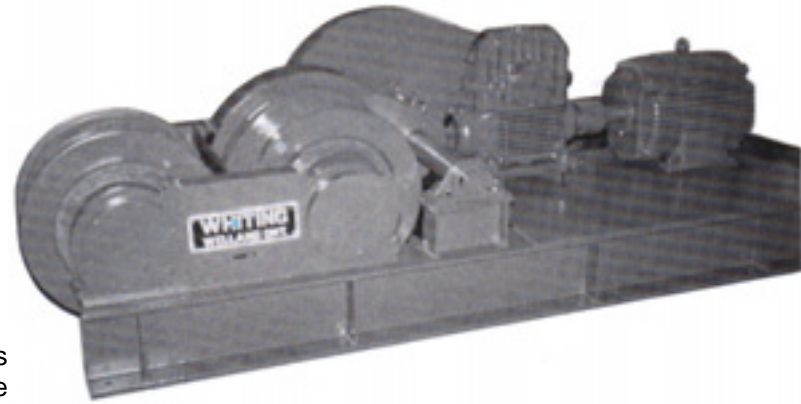

Double drum continuous rope pullers are available in sizes with starting line pulls up to 70,000 pounds. These units were designed for applications where cars must be moved over extended distances and where the service is frequent. All sizes are of narrow frame construction to allow installation in minimal track center locations, for car movement on adjacent tracks. Counterweight towers are used on either side of the puller for slack cable take-up. One or both drums may be driven in this tandem arrangement. Both grooved drums have sufficient

wraps of wire rope to provide the necessary frictional efficiency for the load design.

Cars are attached to the continuous rope by means of a hook and clamp arrangement. Cars can be pulled in either forward or reverse directions.

All bearings are of the antifriction type. Electric motors are of the high torque type with motor control arranged to suit the application.

These continuous rope machines are ideal for use with the ROBOT systems described on Pages 4-7.

## Typical Layout

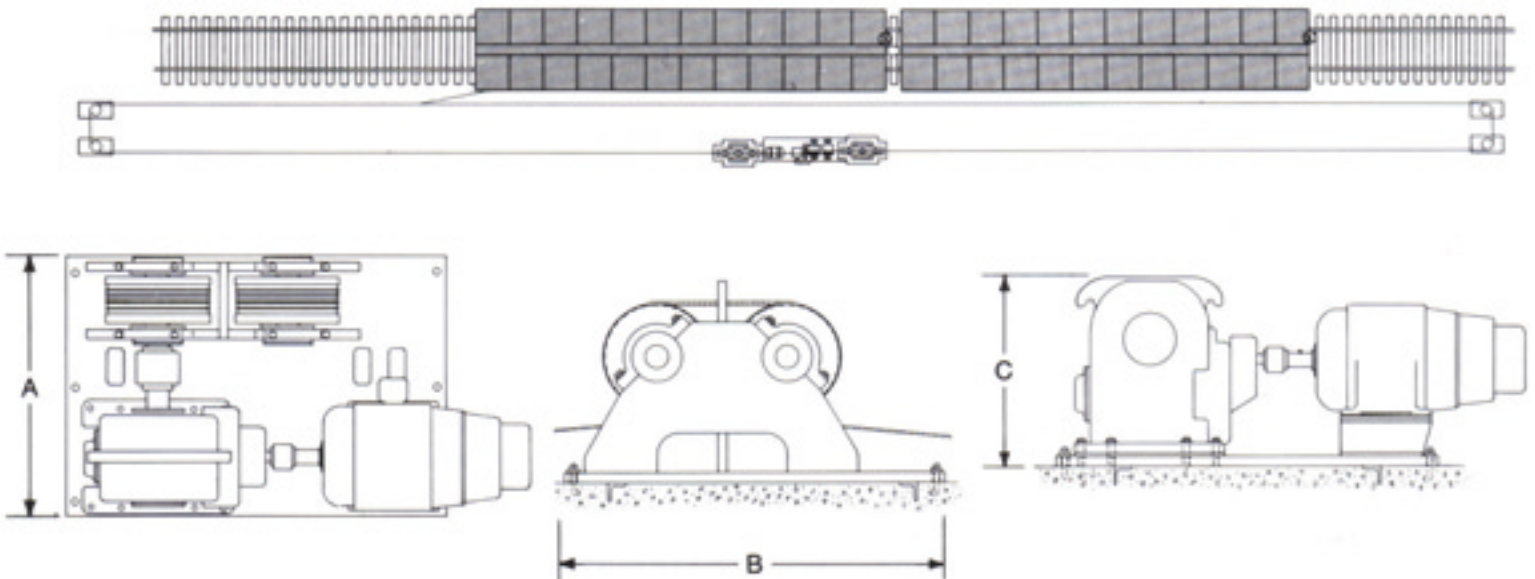

SINGLE GROOVED DRUM PULLER – 2 ROPE							
Capacity		Average Line Speed f.p.m.	H.P.	Rope Size	A	B	C
Run	Start						
3,000	6,000	100	10	½"	3'7"	5'7"	2'9¼"
5,000	10,000	39	7½	¾"	3'7"	5'4"	2'9¼"
10,000	20,000	30	15	¾"	4'4"	12'2½"	3'11⅛"
15,000	30,000	30	20	1"	4'4"	12'2½"	3'11⅛"
20,000	50,000	29	25	1⅛"	4'4"	12'3⅝"	3'11⅛"
25,000	50,000	40	40	1⅛"	4'4"	13'7"	4'2¼"
35,000	70,000	30	50	1½"	4'8⅞"	22'0"	6'1¾"

# From WHITING....

## Complete Engineering Services, Equipment and Systems For High Efficiency Car/Locomotive Maintenance

Imaginative engineering by **Whiting Equipment Canada Inc.** has created systems for locomotive and car maintenance that provide significant savings in cost and time. They include:

### Car Progression Systems

Mobile and cable type car pulling equipment - this is including the company's ROBOT Remote Control System, a technical breakthrough. Using endless rope car pullers and wheeled devices in double channel track, it features robot arms that raise to contact axle or journal of cars to be moved. Robot advantages include remote control of entire progression system from central console, automatic cycling of progression sequences, no cables to handle or hooks to slip loose, puller rope completely enclosed for safety, automatic car indexing.

### Car and Locomotive Jacking

Portable electric jacks in 10, 16, 25, 35, 50, and 60-ton capacities, with an exceptionally high safety factor of 5. Interlocking controls permit operation in unison in series of two or four from portable pushbutton station.

### Train Washing

Train washers designed to meet specific requirements, with a variety of brush arrangements to handle all types of equipment including the new lightweight trains, dome cars, and diesel-electric locomotives with car contour. Interior washers for covered hopper cars - at the washing station, underhung crane lowers into the car a washing wand equipped with a roto jet nozzle that sprays 140 gallons (630 litres) of water per minute through four jet outlets at 400 psi (27 bar) pressure.

### Drop Tables

Drop Tables for use in removing trucks from under locomotives, coaches, or freight rolling stock. Designs adaptable to every service requirement: installations new serve pits from 4 to 26 feet wide (1.2 to 7.9 m); capacities range from 20 to 150 tons. Electrical power controls all operations.

### Railcar Repair Systems

One Spot car repair system expedites riptrack work, slashes labour costs, reduces bad order delays, and all but eliminates switch engine hours. Design and layout, and variety of equipment are available to suit specific requirements.

### Transfer and Turntables

Transfer tables - to move railway rolling stock from one parallel track to any of a number of other parallel tracks without the use of switches and excess property requirements. Has application for carrier loading at plants, reducing damage to such products as automobiles.

### Locomotive Sanding

Sand bridges - one man can service five locomotives with four sand boxes in 18 minutes. Sanding gantry rides on parallel tracks straddling two rail spurs. Pushbutton controls move platform vertically and horizontally. Hoses of various lengths from the hopper enable the operator to fill sand boxes in any location.

### Multiple Car Hoists

Hoisting equipment - a variety of arrangements to speed maintenance, reduce costs and down time. Electric motor operated multi-hoist units can be arranged to lift coupled cars. All units synchronized and interlocked to maintain minimum elevation variations.



- **Rail/Rapid Transit Maintenance Equipment** car progression and repair systems, turntables, washers, jacks
- **Chemical Process Equipment** including Swenson evaporators, crystallisers, dryers
- **Metallurgical Equipment** complete melt shop equipment from Electric arc furnaces to ladles
- **Material Handling** light to heavy duty cranes, roller, Belt and telescopic conveyors
- **Trackmobile®** bi-modal transport system providing an efficient and economical means of switching railcars within industrial plants and railroad terminals.

## **Whiting Equipment Canada Inc.**



[www.whiting.ca](http://www.whiting.ca)

### **Richard Breznik**

350 Alexander Street  
Welland, Ontario L3B 2R2 CDN  
Tel (+1) 905-732-7585 ext. 256  
Fax (+1) 905-732-2366  
E-Mail: [rbreznik@whiting.ca](mailto:rbreznik@whiting.ca)